

PLAN

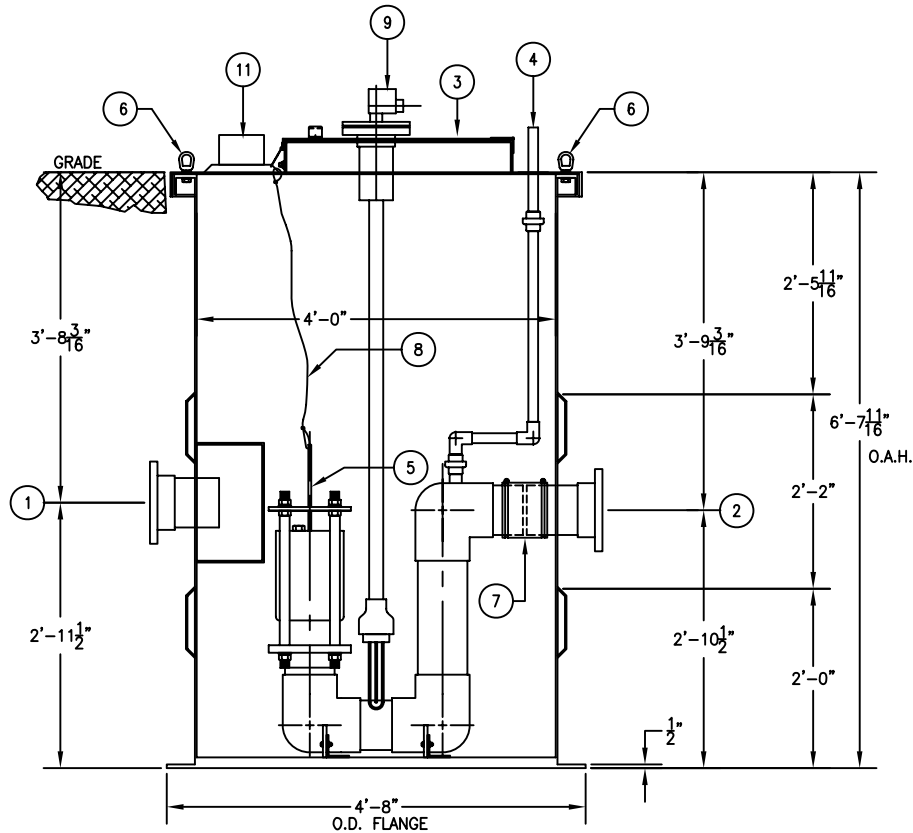

SECTION "A-A"

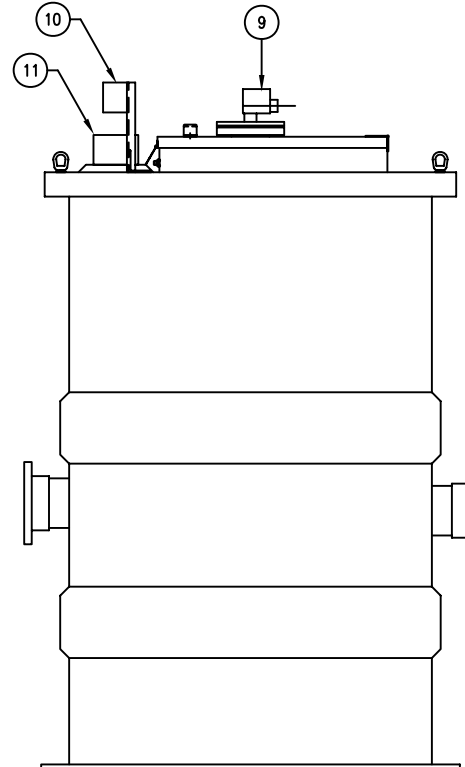

SIDE ELEVATION

APPROX. UNIT WT. 700 LBS.

ASSEMBLY LIST

- ① 6"Ø INLET, FLANGED
- ② 6"Ø OUTLET, FLANGED
- ③ 2'-6" x 2'-6" MANWAY
- ④ 1"Ø VENT/SIPHON BREAKER
- ⑤ 6"Ø OIL STOP VALVE
- ⑥ LIFTING LUG (2 REQ'D)
- ⑦ 6"Ø FLEXIBLE CONNECTOR
- ⑧ FLOAT LIFT CABLE
- ⑨ 1 1/2 KW HEATER, FLANGED
- ⑩ THERMOSTAT
- ⑪ JUNCTION BOX
- ⑫ CONTROL PANEL(REMOTE)

NOTES

1. PIPE AND FITTINGS ARE TO BE ONE OF THE FOLLOWING TYPES:
SCH. 40, PVC - STANDARD
SCH. 80, PVC
SCH. 40, CPVC
SCH. 80, CPVC
SCH. 80, PVC
FRP BISPHENOL
FRP VINYL ESTER
2. TANKS ARE TO BE CONSTRUCTED WITH ONE OF THE FOLLOWING RESIN TYPES:
ISOPHTHALIC POLYESTER - STANDARD
BISPHENOL A - POLYESTER
HETRON 197-A
3. MODIFICATIONS AND SPECIAL EQUIPMENT TO SUITE SPECIFIC CUSTOMER REQUIREMENTS ARE AVAILABLE BY FACTORY UPON APPROVAL BY AFL'S ENGINEERING DEPARTMENT.
4. ALL EXTERNAL CONNECTIONS ARE ANSI FLANGES, 150 LB. FLAT FACED.
5. ALL NOZZLE PROJECTIONS ARE 6" UNLESS NOTED OTHERWISE.
6. AFL REQUIRES A FLEXIBLE COUPLING INSTALLED BETWEEN THE TANK AND CUSTOMERS CONNECTING PIPES TO ELIMINATE EXCESSIVE LOADING ON TANK FLANGES.
7. TANK FABRICATED WITH A BOTTOM FLANGE FOR ANCHORING. (OPTIONAL)

 AFL INDUSTRIES, INC. 1751 WEST 10TH STREET, RIVIERA BEACH, FLA. 33404		
SCALE: NONE	THIS DRAWING AND SPECIFICATIONS IS THE PROPERTY OF AFL INDUSTRIES, 1751 WEST 10TH STREET RIVIERA BEACH, FLA. 33404 AND SHALL NOT BE REPRODUCED WITHOUT WRITTEN PERMISSION.	DRAWN BY: TMB
DATE: 5/18/07		CHECKED BY:
MODEL: SOS-6 W/ FREEZE PROTECTION		AFL JOB No. 5204
JOB: AFL INDUSTRIES	DRAWING No. 3S2567	FILE: SOS-6P 5/18/07