

PLAN

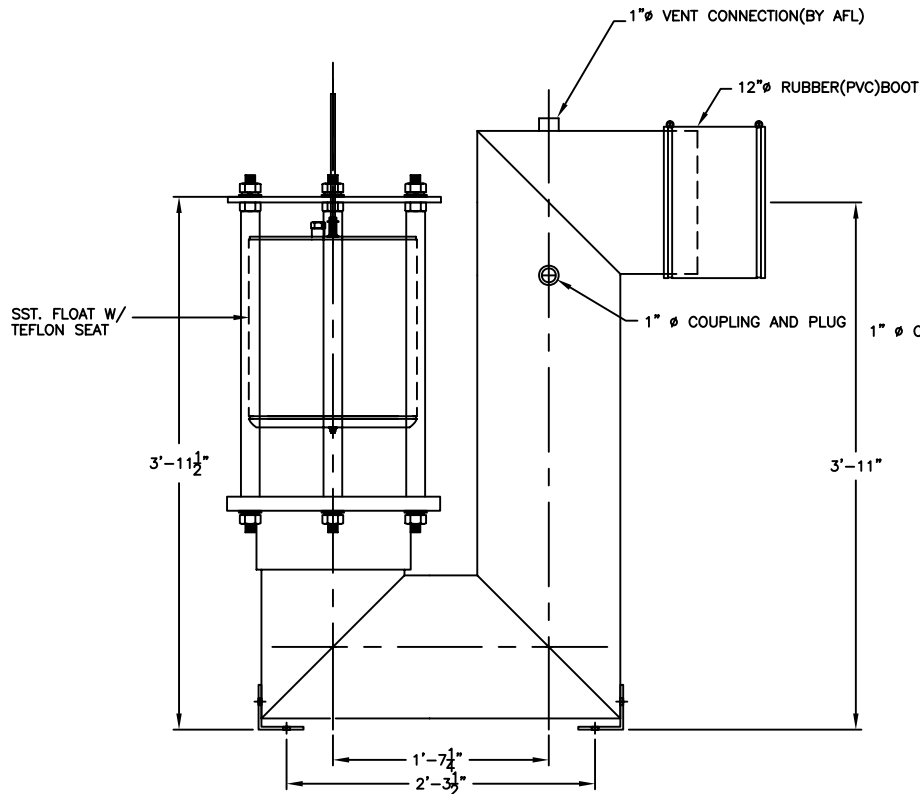

SIDE VIEW

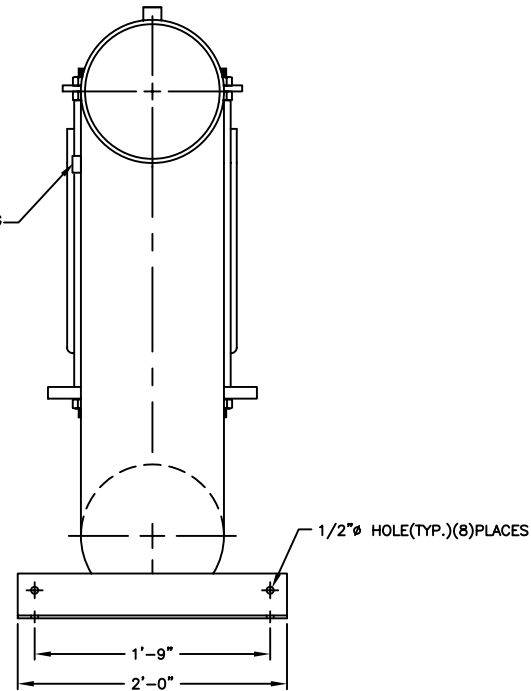

OUTLET VIEW

NOTES

FOR PROPER VALVE OPERATION THE STEPS AS LISTED BELOW MUST BE FOLLOWED:

1. VENT PIPE IS TO BE FURNISHED BY CUSTOMER AND MUST EXTEND ABOVE CONTAINMENT AREA.
2. AFTER VALVE IS INSTALLED, THE SUMP MUST BE FILLED WITH WATER UNTIL THE LIQUID LEVEL IS AT THE INVERT OF DISCHARGE PIPE.
3. MANUALLY OPEN VALVE BY LIFTING THE FLOAT IN A VERTICAL DIRECTION ONLY. TO FACILITATE MANUAL OPENING OF THE VALVE ATTACH 1/16" Ø WIRE TO FLOAT STEM AND THE OTHER END TO A EASILY ACCESSIBLE AREA. MAKE SURE THERE IS ENOUGH SLACK IN WIRE FOR THE VALVE(FLOAT) TO CLOSE.
4. AFTER A SPILL, THE SPILLED LIQUID MUST BE EVACUATED UNTIL WATER ONLY IS IN THE SUMP. ADD WATER IF WATER LEVEL IS BELOW THE INVERT.(SEE NOTE#2)
5. MANUALLY REOPEN VALVE.
6. FOR ADDITIONAL INSTRUCTIONS REFER TO INSTALLATION, OPERATION, & MAINTENANCE(I-O-M) MANUAL.

FAILURE TO FOLLOW ABOVE PROCEDURES MAY CAUSE OIL TO BE DISCHARGED.

DIMENSIONAL TOLERANCE ± 1/8"



INDUSTRIES, INC.
1751 WEST 10TH STREET, RIVIERA BEACH, FLA. 33404

SCALE: NONE	THIS DRAWING AND SPECIFICATION IS THE PROPERTY OF AFL INDUSTRIES, 1751 WEST 10TH STREET, RIVIERA BEACH, FLA. 33404 AND SHALL NOT BE REPRODUCED WITHOUT WRITTEN PERMISSION.	DRAWN BY: TMB
DATE: 7/20/04		CHECKED BY:
MODEL: 12" Ø SST. OIL STOP VALVE W/O SLAVE VALVE		AFL JOB No. 5204
JOB: AFL INDUSTRIES	DRAWING No. 3S2537	
		FILE: 08-1225 1.5-12 7/20/04