

NOTE:
CONFIRM LOCATIONS OF HINGES
OPTIONAL LOCATIONS A,B,C,OR D

ASSEMBLY LIST

- ① 6" # INLET, FLANGED
- ② 6" # OUTLET, FLANGED
- ③ 6" # OIL OUTLET, FLANGED
- ④A 2'-0" X 5'-6" MANWAY
- ④B 2'-0" X 2'-0" MANWAY
- ⑤ 2" # SLUDGE DRAW-OFF, FLANGED
- ⑥ INLET BAFFLE
- ⑦ VERTICAL TUBE COALESCERS
- ⑧ OIL RETENTION BAFFLE
- ⑨ SHEEN BAFFLE
- ⑩ ADJUSTABLE OUTLET WEIR
- ⑪ 2" # VENT, FLANGED
- ⑫ 6" # ROTARY PIPE SKIMMER
- ⑬ HOLD DOWNS(OPTIONAL)

NOTES

1. WITHOUT WRITTEN CONSENT FROM AFL INDUSTRIES, INC., DO NOT:
 - A. DRILL HOLES OR OTHERWISE PUNCTURE THE FIBERGLASS SKINS OF THE UNIT.
 - B. MOUNT ANY EQUIPMENT OR ACCESSORY ON THE UNIT.
 - C. REMOVE ANY EQUIPMENT OR ACCESSORY FROM THE UNIT.
 - D. FLOOD THE UNIT OR RESTRICT THE OUTFLOWS.
2. AFL REQUIRES A FLEXIBLE COUPLING TO BE INSTALLED BETWEEN THE TANK AND CUSTOMER'S CONNECTING PIPES TO ELIMINATE EXCESSIVE LOADING ON TANK FLANGES.
3. DIMENSIONAL TOLERANCE ± 1/2".
4. ALL TANK FLANGES FURNISHED BY AFL ARE 150 LB. FLAT FACE FLANGES.
5. ALL NOZZLE PROJECTIONS ARE 6" UNLESS NOTED OTHERWISE.
6. ALL FLANGE BOLT HOLE PATTERNS TO STRADDLE CENTERLINES.

PLAN

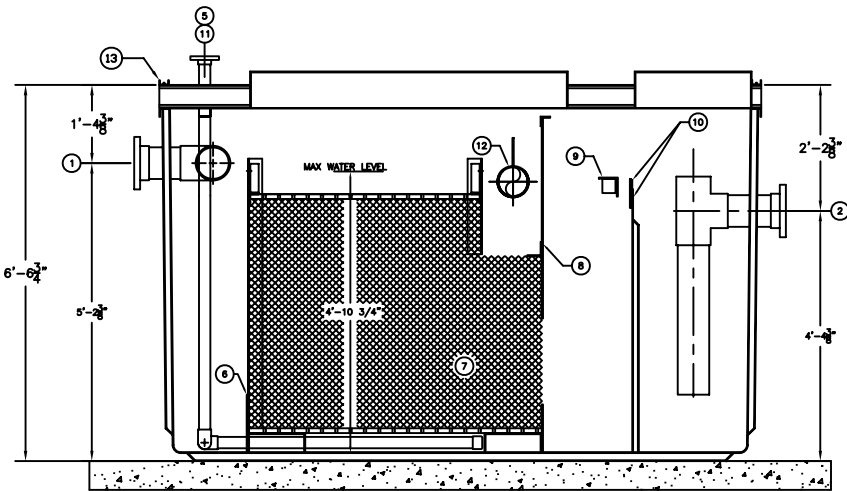

SECTION "A-A"

APPROX. UNIT WT. = 1,600 LBS.

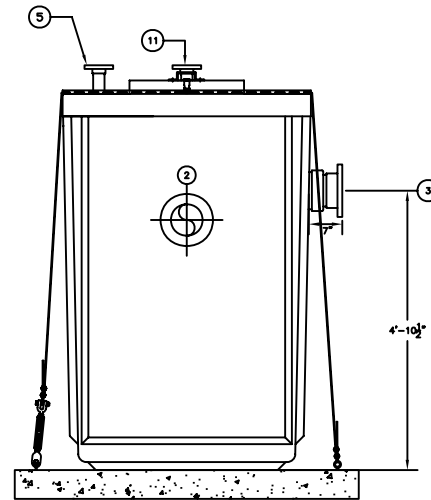

OUTLET END ELEVATION

NOTE:
CONCRETE PAD & ANCHOR
BOLTS NOT BY AFL

 AFL INDUSTRIES, INC. 1751 WEST 10TH STREET, RIVERA BEACH, FLA. 33404		
MODEL: NONE DATE: 6/26/07 DRAWN BY:	CHECKED BY: DESIGNED BY: APPROVED BY:	DRAWN ON: TMB SCALE: AS SHOWN PART NO.: 5204
VTC-200F		
AFL INDUSTRIES		DRAWING NO.: 451820 FILE NO.: 451820