

### ASSEMBLY LIST

- ① 4"  $\phi$  INLET, FLANGED
- ② 4"  $\phi$  OUTLET, FLANGED
- ③ 3"  $\phi$  OIL OUTLET, FLANGED
- ④A 5'-0" x 2'-6" MANWAY
- ④B 1'-6" x 5'-0" MANWAY
- ⑤ INLET BAFFLE
- ⑥ VERTICAL TUBE COALESCERS
- ⑦ OIL RETENTION BAFFLE
- ⑧ SHEEN BAFFLE
- ⑨ ADJUSTABLE OUTLET WEIR
- ⑩ ROTARY PIPE SKIMMER
- ⑪ 2"  $\phi$  SLUDGE DRAW OFF, FLANGED
- ⑫ 2"  $\phi$  VENT, FLANGED
- ⑬ HOLD DOWNS (OPTIONAL)

### NOTES

1. WITHOUT WRITTEN CONSENT FROM AFL INDUSTRIES, INC., DO NOT:
  - A. DRILL HOLES OR OTHERWISE PUNCTURE THE FIBERGLASS SKINS OF THE UNIT.
  - B. MOUNT ANY EQUIPMENT OR ACCESSORY ON THE UNIT.
  - C. REMOVE ANY EQUIPMENT OR ACCESSORY FROM THE UNIT.
  - D. FLOOD THE UNIT OR RESTRICT THE OUTFLOWS.
2. AFL REQUIRES A FLEXIBLE COUPLING TO BE INSTALLED BETWEEN THE TANK AND CUSTOMER'S CONNECTING PIPES TO ELIMINATE EXCESSIVE LOADING ON TANK FLANGES.
3. DIMENSIONAL TOLERANCE  $\pm 1/2"$ .
4. ALL TANK FLANGES FURNISHED BY AFL ARE 150# FLAT FACE FLANGES.
5. ALL NOZZLE PROJECTIONS ARE 4" UNLESS NOTED OTHERWISE.
6. ALL FLANGE BOLT HOLE PATTERNS TO STRADDLE CENTERLINES.

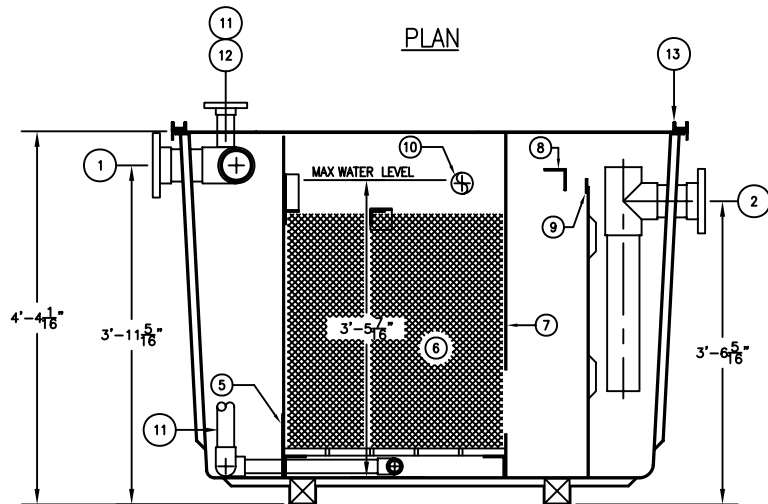

SECTION "A" - "A"

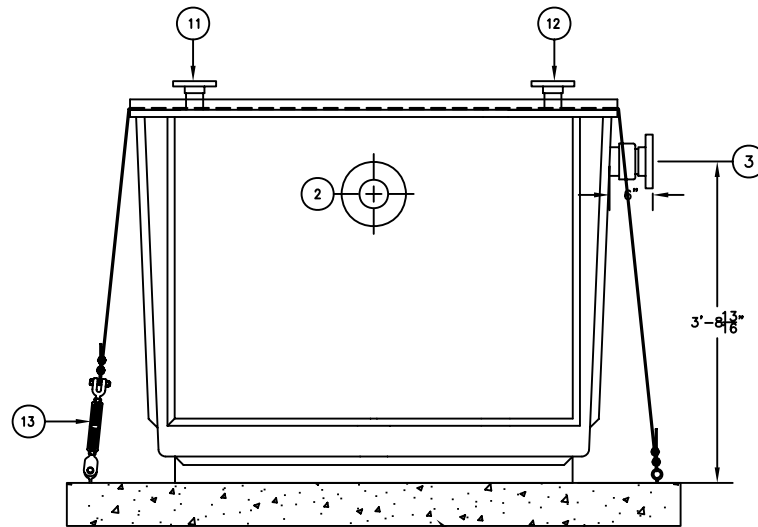

ELEVATION  
OUTLET END

CONCRETE SLAB & ANCHOR BOLTS  
(NOT BY AFL)

APPROX. UNIT WT: 650#

 <b>AFL INDUSTRIES, INC.</b> 1751 WEST 10TH STREET, RIVIERA BEACH, FLA. 33404		
SCALE: NONE	THE DRAWING AND SPECIFICATIONS IS THE PROPERTY OF AFL INDUSTRIES, 1751 WEST 10TH STREET, RIVIERA BEACH, FLA. 33404 AND SHALL NOT BE REPRODUCED WITHOUT WRITTEN PERMISSION.	DRAWN BY: TMB
DATE: 6/26/07		CHECKED BY:
MODEL: VTC-50F		AFL JOB No. 5204
JOB: AFL INDUSTRIES	DRAWING No. 3S2587	
	FILE: VTC-50F 6/26/07	