

NOTE:  
CONFIRM LOCATIONS OF HINGES  
OPTIONAL LOCATIONS A,B,C,OR D

**ASSEMBLY LIST**

- ① 8" # INLET, FLANGED
- ② 8" # OUTLET, FLANGED
- ③ 6" # OIL OUTLET, FLANGED
- ④A 4'-0" X 5'-6" MANWAY
- ④B 4'-0" X 2'-0" MANWAY
- ⑤ 2" # DRAIN, FLANGED (3 REQ'D.)
- ⑥ INLET BAFFLE
- ⑦ VERTICAL TUBE COALESCERS
- ⑧ OIL RETENTION BAFFLE
- ⑨ SHEEN BAFFLE
- ⑩ ADJUSTABLE OUTLET WEIR
- ⑪ 2" # VENT, FLANGED
- ⑫ 6" # ROTARY PIPE SKIMMER

**NOTES**

1. WITHOUT WRITTEN CONSENT FROM AFL INDUSTRIES, INC., DO NOT:
  - A. DRILL HOLES OR OTHERWISE PUNCTURE THE FIBERGLASS SKINS OF THE UNIT.
  - B. MOUNT ANY EQUIPMENT OR ACCESSORY ON THE UNIT.
  - C. REMOVE ANY EQUIPMENT OR ACCESSORY FROM THE UNIT.
  - D. FLOOD THE UNIT OR RESTRICT THE OUTFLOWS.
2. AFL REQUIRES A FLEXIBLE COUPLING TO BE INSTALLED BETWEEN THE TANK AND CUSTOMER'S CONNECTING PIPES TO ELIMINATE EXCESSIVE LOADING ON TANK FLANGES.
3. DIMENSIONAL TOLERANCE  $\pm 1/2"$ .
4. ALL TANK FLANGES FURNISHED BY AFL ARE 150 lb. FLAT FACE FLANGES.
5. ALL NOZZLE PROJECTIONS ARE 6" UNLESS NOTED OTHERWISE.
6. ALL FLANGE BOLT HOLE PATTERNS TO STRADDLE CENTERLINES.

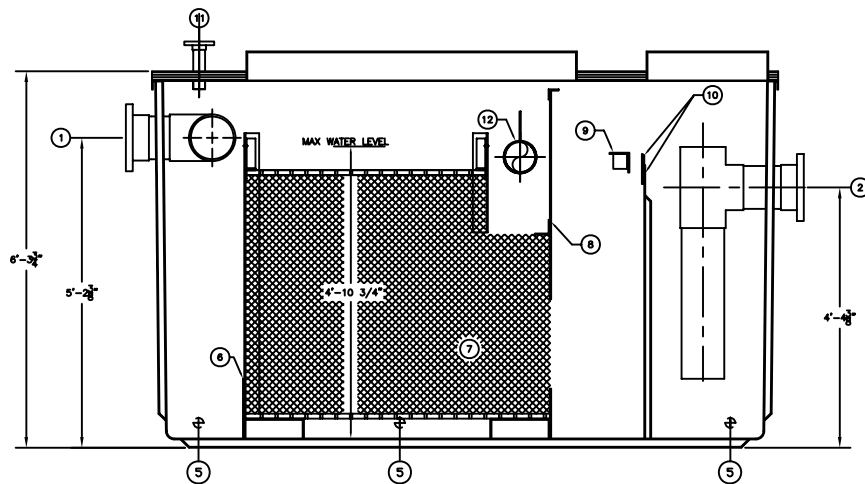

APPROX. UNIT WT. = 2,050 LBS.

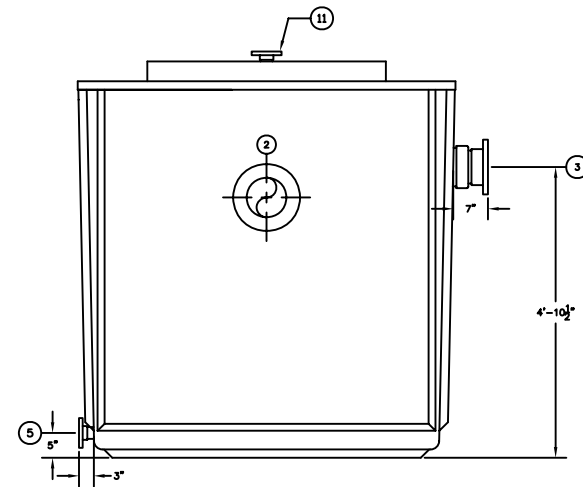

<b>AFL INDUSTRIES, INC.</b>	
1751 WEST 10TH STREET, RIVIERA BEACH, FLA. 33404	
MODEL: NONE	DATE: 6/26/07
REV: 6/26/07	REV: 5204
<b>VTC-300A</b>	
5204	
AFL INDUSTRIES 451822	