

NOTE:
CONFIRM LOCATIONS OF HINGES
OPTIONAL LOCATIONS A,B,C,OR D

ASSEMBLY LIST

- ① 6" # INLET, FLANGED
- ② 6" # OUTLET, FLANGED
- ③ 6" # OIL OUTLET, FLANGED
- ④A 2'-0" X 5'-6" MANWAY
- ④B 2'-0" X 2'-0" MANWAY
- ⑤ 2" # DRAIN, FLANGED (3 REQ'D.)
- ⑥ INLET BAFFLE
- ⑦ VERTICAL TUBE COALESCERS
- ⑧ OIL RETENTION BAFFLE
- ⑨ SHEEN BAFFLE
- ⑩ ADJUSTABLE OUTLET WEIR
- ⑪ 2" # VENT, FLANGED
- ⑫ 6" # ROTARY PIPE SKIMMER

NOTES

1. WITHOUT WRITTEN CONSENT FROM AFL INDUSTRIES, INC., DO NOT:
 - A. DRILL HOLES OR OTHERWISE PUNCTURE THE FIBERGLASS SKINS OF THE UNIT.
 - B. MOUNT ANY EQUIPMENT OR ACCESSORY ON THE UNIT.
 - C. REMOVE ANY EQUIPMENT OR ACCESSORY FROM THE UNIT.
 - D. FLOOD THE UNIT OR RESTRICT THE OUTFLOWS.
2. AFL REQUIRES A FLEXIBLE COUPLING TO BE INSTALLED BETWEEN THE TANK AND CUSTOMER'S CONNECTING PIPES TO ELIMINATE EXCESSIVE LOADING ON TANK FLANGES.
3. DIMENSIONAL TOLERANCE ± 1/2".
4. ALL TANK FLANGES FURNISHED BY AFL ARE 150 LB. FLAT FACE FLANGES.
5. ALL NOZZLE PROJECTIONS ARE 6" UNLESS NOTED OTHERWISE.
6. ALL FLANGE BOLT HOLE PATTERNS TO STRADDLE CENTERLINES.

PLAN

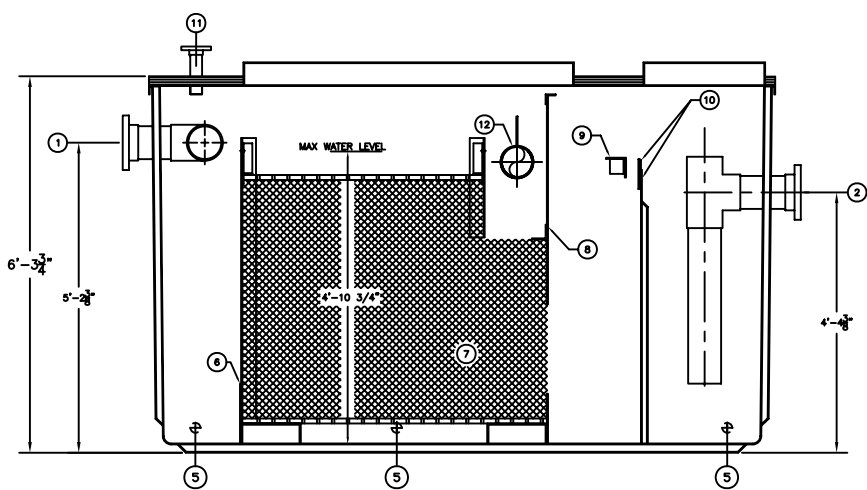

SECTION "A-A"

APPROX. UNIT WT. = 1,600 LBS.

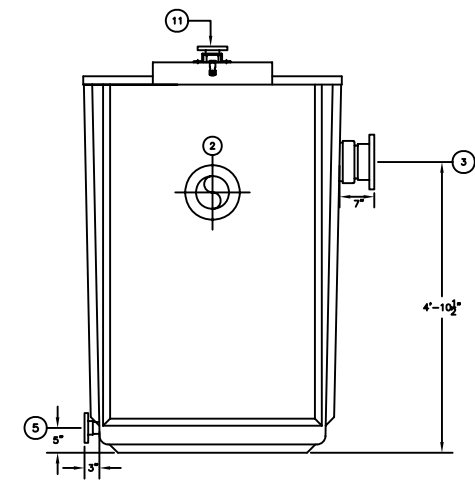

OUTLET END ELEVATION

1751 WEST 10TH STREET, RIVIERA BEACH, FLA. 33404	
MODEL: NONE DATE: 6/26/07	DRAWN BY: TMB CHECKED BY: DATE: 6/26/07
VTC-200A	5204
AFL INDUSTRIES	4S1818 <small>Rev 10-2004 04/07</small>