

NOTE:  
CONFIRM LOCATIONS OF HINGES  
OPTIONAL LOCATIONS A,B,C,OR D

**ASSEMBLY LIST**

- ① 6" # INLET, FLANGED
- ② 6" # OUTLET, FLANGED
- ③ 6" # OIL TRANSFER PIPE
- ④A 4'-0" X 5'-6" MANWAY
- ④B 5'-0" X 2'-0" MANWAY
- ⑤ 2" # DRAIN, FLANGED (3 REQ'D.)
- ⑥ INLET BAFFLE
- ⑦ VERTICAL TUBE COALESCEERS
- ⑧ OIL RETENTION BAFFLE
- ⑨ SHEEN BAFFLE
- ⑩ ADJUSTABLE OUTLET WEIR
- ⑪ 2" # VENT, FLANGED
- ⑫ 6" # ROTARY PIPE SKIMMER
- ⑬ VTC-200
- ⑭ OIL STORAGE CHAMBER
- ⑮ PARTITION WALL
- ⑯ 3" # OIL DRAW OFF, FLANGED W/ BLIND FLANGE

**NOTES**

1. WITHOUT WRITTEN CONSENT FROM AFL INDUSTRIES, INC., DO NOT:
  - A. DRILL HOLES OR OTHERWISE PUNCTURE THE FIBERGLASS SKINS OF THE UNIT.
  - B. MOUNT ANY EQUIPMENT OR ACCESSORY ON THE UNIT.
  - C. REMOVE ANY EQUIPMENT OR ACCESSORY FROM THE UNIT.
  - D. FLOOD THE UNIT OR RESTRICT THE OUTFLOWS.
2. AFL REQUIRES A FLEXIBLE COUPLING TO BE INSTALLED BETWEEN THE TANK AND CUSTOMER'S CONNECTING PIPES TO ELIMINATE EXCESSIVE LOADING ON TANK FLANGES.
3. DIMENSIONAL TOLERANCE ± 1/2".
4. ALL TANK FLANGES FURNISHED BY AFL ARE 150 LB. FLAT FACE FLANGES.
5. ALL NOZZLE PROJECTIONS ARE 6" UNLESS NOTED OTHERWISE.
6. ALL FLANGE BOLT HOLE PATTERNS TO STRADDLE CENTERLINES.

**PLAN**

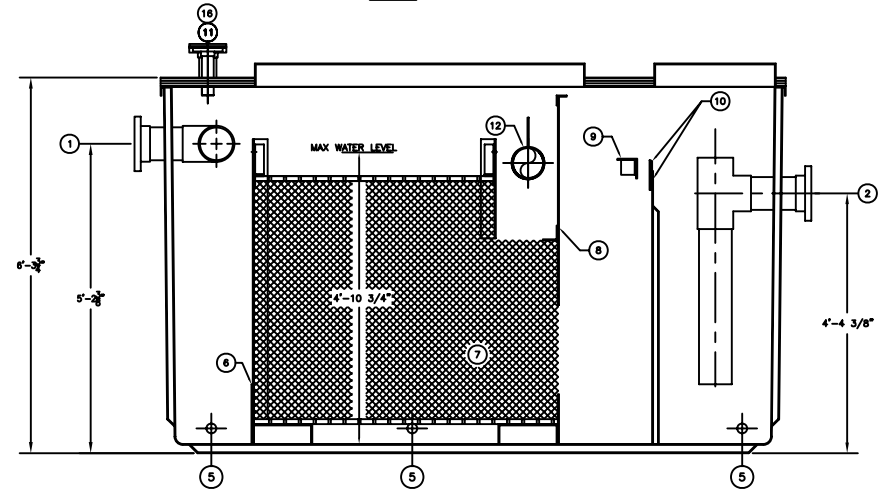

**SECTION "A-A"**

APPROX. UNIT WT. = 2,250 LBS.

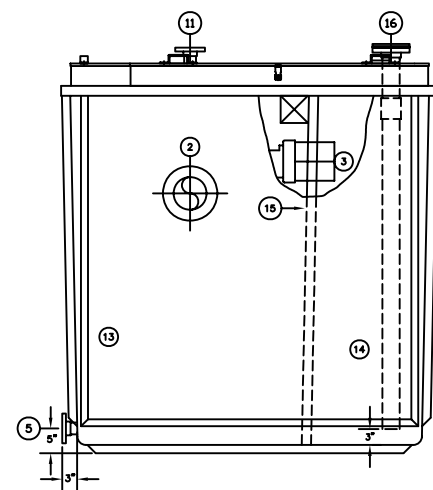

**OUTLET END ELEVATION**

AFL INDUSTRIES, INC. 1751 WEST 10TH STREET, ROYAL BEACH, FLA. 33404	
MODEL: NONE DATE: 6/26/07	DRAWN BY: TMB CHECKED BY: DATE:
<b>VTC-200A2</b>	<b>5204</b>
AFL INDUSTRIES	451819 <small>ALL RIGHTS RESERVED</small>