

PLAN

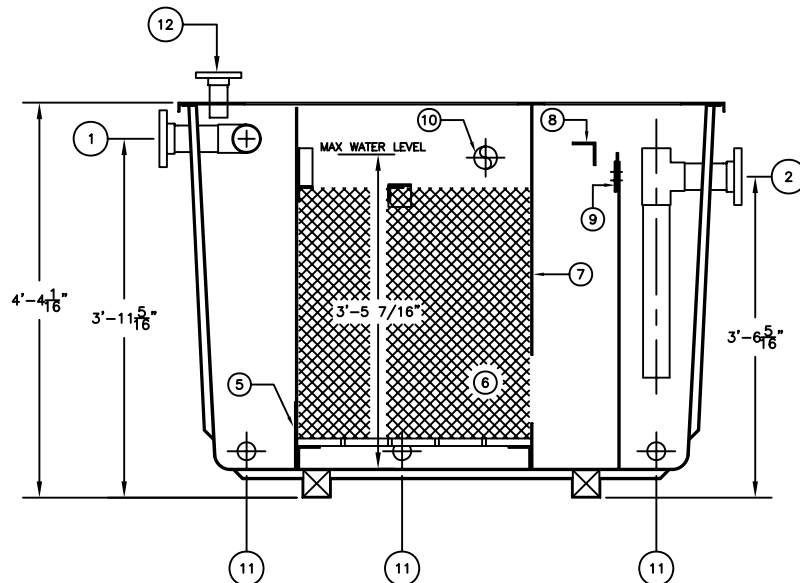

SECTION "A"-"A"

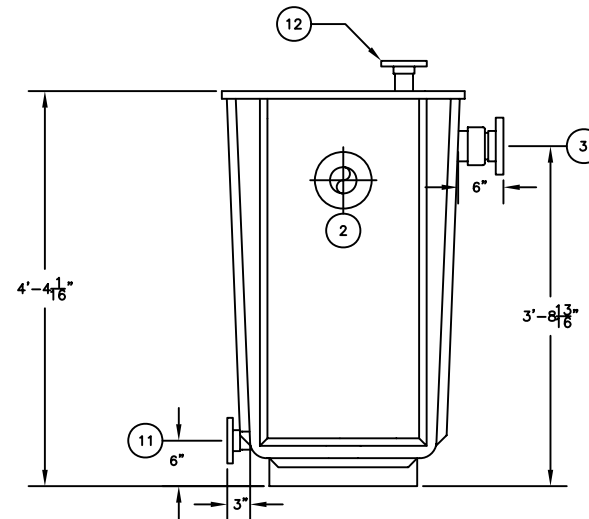

END OUTLET ELEVATION

**ASSEMBLY LIST**

- ① 3"Ø INLET, FLANGED
- ② 3"Ø OUTLET, FLANGED
- ③ 3"Ø OIL OUTLET, FLANGED
- ④A 2'-0" x 3'-0" MANWAY
- ④B 1'-6" x 2'-0" MANWAY
- ⑤ INLET BAFFLE
- ⑥ VERTICAL TUBE COALESCERS
- ⑦ OIL RETENTION BAFFLE
- ⑧ SHEEN BAFFLE
- ⑨ ADJUSTABLE OUTLET WEIR
- ⑩ ROTARY PIPE SKIMMER
- ⑪ 2"Ø DRAIN, FLANGED (3 REQ'D.)
- ⑫ 2"Ø VENT, FLANGED

**NOTES**

1. WITHOUT WRITTEN CONSENT FROM AFL INDUSTRIES, INC., DO NOT:
  - A. DRILL HOLES OR OTHERWISE PUNCTURE THE FIBERGLASS SKINS OF THE UNIT.
  - B. MOUNT ANY EQUIPMENT OR ACCESSORY ON THE UNIT.
  - C. REMOVE ANY EQUIPMENT OR ACCESSORY FROM THE UNIT.
  - D. FLOOD THE UNIT OR RESTRICT THE OUTFLOWS.
2. AFL REQUIRES A FLEXIBLE COUPLING TO BE INSTALLED BETWEEN THE TANK AND CUSTOMER'S CONNECTING PIPES TO ELIMINATE EXCESSIVE LOADING ON TANK FLANGES.
3. DIMENSIONAL TOLERANCE ± 1/2".
4. ALL TANK FLANGES FURNISHED BY AFL ARE 150# FLAT FACE FLANGES.
5. ALL NOZZLE PROJECTIONS ARE 4" UNLESS NOTED OTHERWISE.
6. ALL FLANGE BOLT HOLE PATTERNS TO STRADDLE CENTERLINES.

APPROX. UNIT WT. 400 LBS.

 <b>INDUSTRIES, INC.</b> 1751 WEST 10TH STREET, RIVIERA BEACH, FLA. 33404		
SCALE: NONE	<small>THIS DRAWING AND SPECIFICATIONS ARE THE PROPERTY OF AFL INDUSTRIES, 1751 WEST 10TH STREET, RIVIERA BEACH, FLA. 33404 AND SHALL NOT BE REPRODUCED WITHOUT WRITTEN PERMISSION.</small>	DRAWN BY: TMB
DATE: 6/26/07		CHECKED BY:
MODEL: VTC-20A		AFL JOB No. 5204
JOB: AFL INDUSTRIES	DRAWING No. 3S2582	FILE: VTC-20A 6/26/07